

# Part Diagram

Model No.TW0350 IMPACT WRENCH

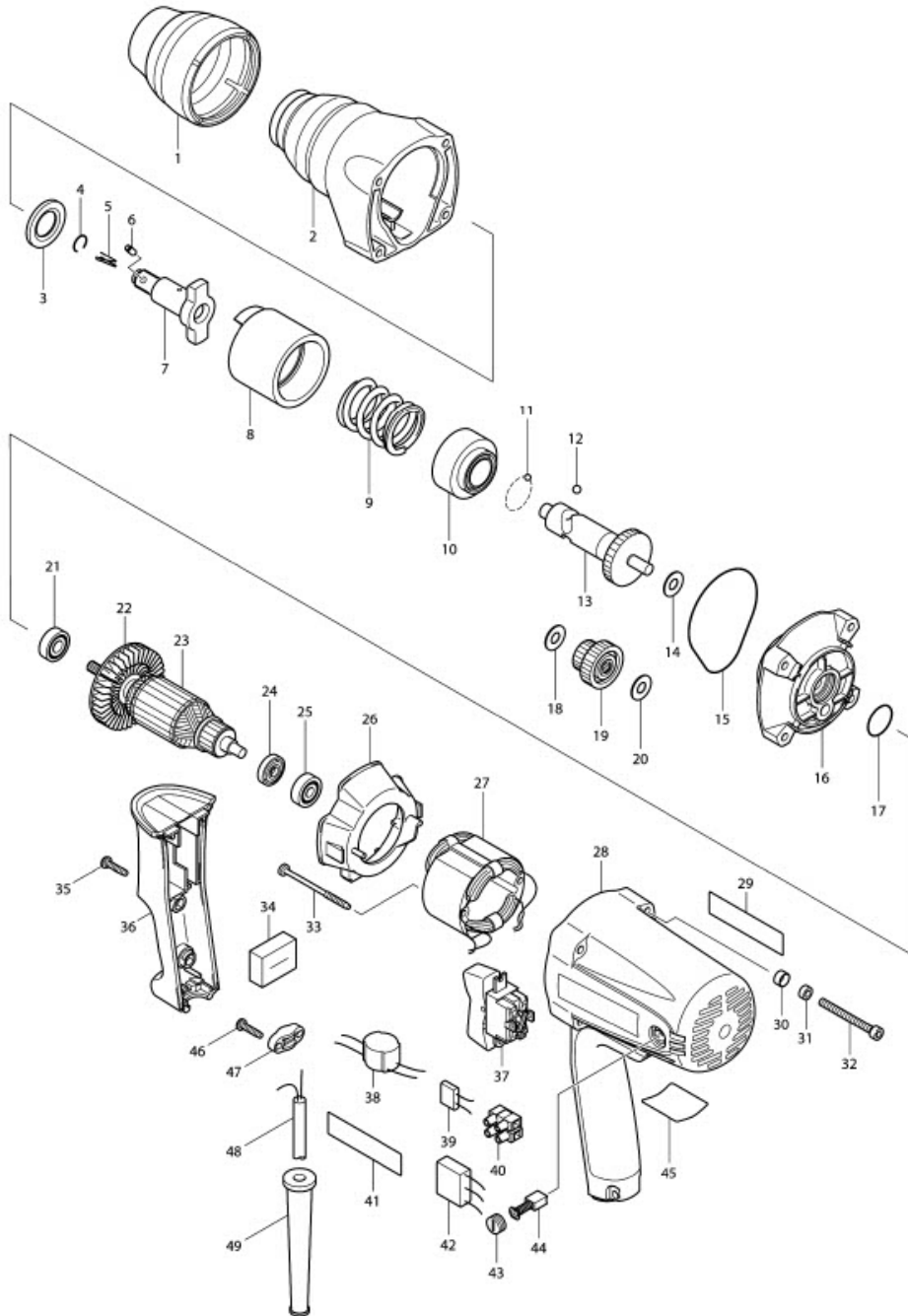

Item	Sub	Parts No.	Parts Description	Qty
1		421837-6	BUMPER	1
2		153623-4	HAMMER CASE COMPLETE	1
2	C10	213257-6	OIL SEAL 18	1
2	C20	321119-5	SLEEVE 18	1
3		267268-3	FLAT WASHER 19	1
4		231907-1	RING SPRING 10	1
7		324406-1	ANVIL	1
007-1		326983-9	ANVIL	1
8		324336-6	HAMMER	1
9		233383-5	COMPRESSION SPRING 28	1
10		313115-7	SPRING HOLDER	1
11		216008-6	STEEL BALL 4	19
12		216007-8	STEEL BALL 6.4	2
13		324338-2	SPINDLE	1
14		253139-0	FLAT WASHER 8	1
15		421838-4	SEAL RING	1
16		153624-2	HAMMER CASE COVER COMPLETE	1
17		213373-4	O RING 22	1
18		253139-0	FLAT WASHER 8	1
19		153626-8	SPUR GEAR 19-41 COMPLETE	1
20		253139-0	FLAT WASHER 8	1
21		210024-0	BALL BEARING 608LLU	1
22		241884-9	FAN 60	1
23		515263-0	ARMATURE ASS'Y 220-240V	1
23	D10		INC. 21,22,24,25	
24		681614-0	INSULATION WASHER	1
25		210025-8	BALL BEARING 627LLB	1
26		418180-2	BAFFLE PLATE	1
27		625163-7	FIELD 220-240V	1
28		183604-4	MOTOR HOUSING	1
28	C10	643455-2	BRUSH HOLDER 6X9	2
28	D10		INC. 29,41	
028-1		153625-0	MOTOR HOUSING	1
028-1	C10	643455-2	BRUSH HOLDER 6X9	2
29		819064-1	MAKITA MARK	1
30		253929-1	CUP WASHER 5	4
31		262001-8	URETHANE RING 5	4
32		266331-9	HEX. SOCKET HEAD BOLT M5X50	4
33		266091-3	TAPPING SCREW 4X50	2
35		265995-6	TAPPING SCREW 4X18	2
36		418179-7	HANDLE COVER	1
37		651572-4	SWITCH SL220SD-19	1
41		819064-1	MAKITA MARK	1
43		643550-8	BRUSH HOLDER CAP 5-8	2
44		191940-4	CARBON BRUSH CB-411	1
45		850644-4	NAME PLATE TW0350	1
46		265995-6	TAPPING SCREW 4X18	2
47		687052-4	STRAIN RELIEF	1
48		692527-0	POWER SUPPLY CORD 1.0-2-2.5	1
49		682566-8	CORD GUARD 10	1
A01		824702-2	PLASTIC CARRYING CASE	1
A01	C10	186347-7	SLIDE LATCH SET	1
A02		134841-3	SOCKET 24-45 ASS'Y	1
A02	C10	213399-6	O-RING 25	1
A02	C20	268057-9	PIN 4	1